

**Mr. Flash U191  
BB50 Series**

## Table of Contents

<b>1. Introduction to Mr. Flash</b> .....	<b>1</b>
<b>2. Main Features Overview</b> .....	<b>1</b>
<b>3. Hardware Specification</b> .....	<b>1</b>
3.1 USB Interface .....	1
3.2 NAND Flash Interface .....	1
3.3 OS Support .....	1
3.4 Product Capacity .....	1
<b>4. Block Diagram</b> .....	<b>2</b>
<b>5. Absolute Maximum Ratings</b> .....	<b>2</b>
<b>6. DC Characteristics</b> .....	<b>3</b>
<b>7. Recommended Operating Conditions</b> .....	<b>3</b>
<b>8. Pin Assignments</b> .....	<b>3</b>
<b>9. Physical Specifications</b> .....	<b>4</b>

## Revision History

Revision	Date	History	Remark
A.0	09/11 '06	New Creation	

Important!! Please make sure the driver matches the part number on your pen drive before you download.

Software AP System Requirements. One of following operation systems: Windows 98/98SE/Windows ME/Windows 2000/Windows XP

The advertised memory capacity of this device represents unformatted capacity. Please note that once formatted and due to variations in flash module block limitations, the functional storage space will be lower than the advertised capacity.

"PQI reserves the right to make changes without notification when fit, form, function, quality and reliability are not affected. The data sheets do not constitute contract documents and should not be considered part of the specification for purposes of any warranty."

## 1. Introduction to U191

The **U191** gives you portability and security to offer you a peace of mind. Compatible with USB 2.0 / 1.1 specifications with low power consumption and data protection.

## 2. Main Features Overview

- ◆ Mobile USB flash drive, USB 2.0 compatible
- ◆ Hot swappable, USB Plug & Play compatible
- ◆ LED indicator with three modes: Busy, waiting, and off
- ◆ Multimedia and data storage
- ◆ Support software for password protection, formatting & partitioning (Not Included)

## 3. Product Specification

<b>USB Interface</b>	High-speed USB 2.0 interface; backward compatible with USB 1.1	
<b>NAND Flash Interface</b>	Integrated ECC circuits for 4-bit error correction	
<b>OS Support</b>	No drive is required for Windows ME, 2000,XP or Mac OS 9.x	
<b>Environment</b>		
Temperature	Operating	0°C to 65°C
	Non-Operating	-20°C to 75°C
Vibration	Operating	0.2G
	Non-Operating	15G
Shock resistant	Operating	150G
	Non-Operating	1000G
<b>Configuration</b>		
Capacity		128MBytes ~ 2GBytes
<b>Reliability</b>		
MTBF(@25°C)		1,000,000 hours
<b>Power Requirement</b>		
Voltage		DC 3.3/5V ± 10%
<b>Power Consumption</b>		
Read		<100mA
Write		<120mA
Standby		<100mA
Un-configuration		<100mA
Suspend		<1.5mA

4. Block Diagram

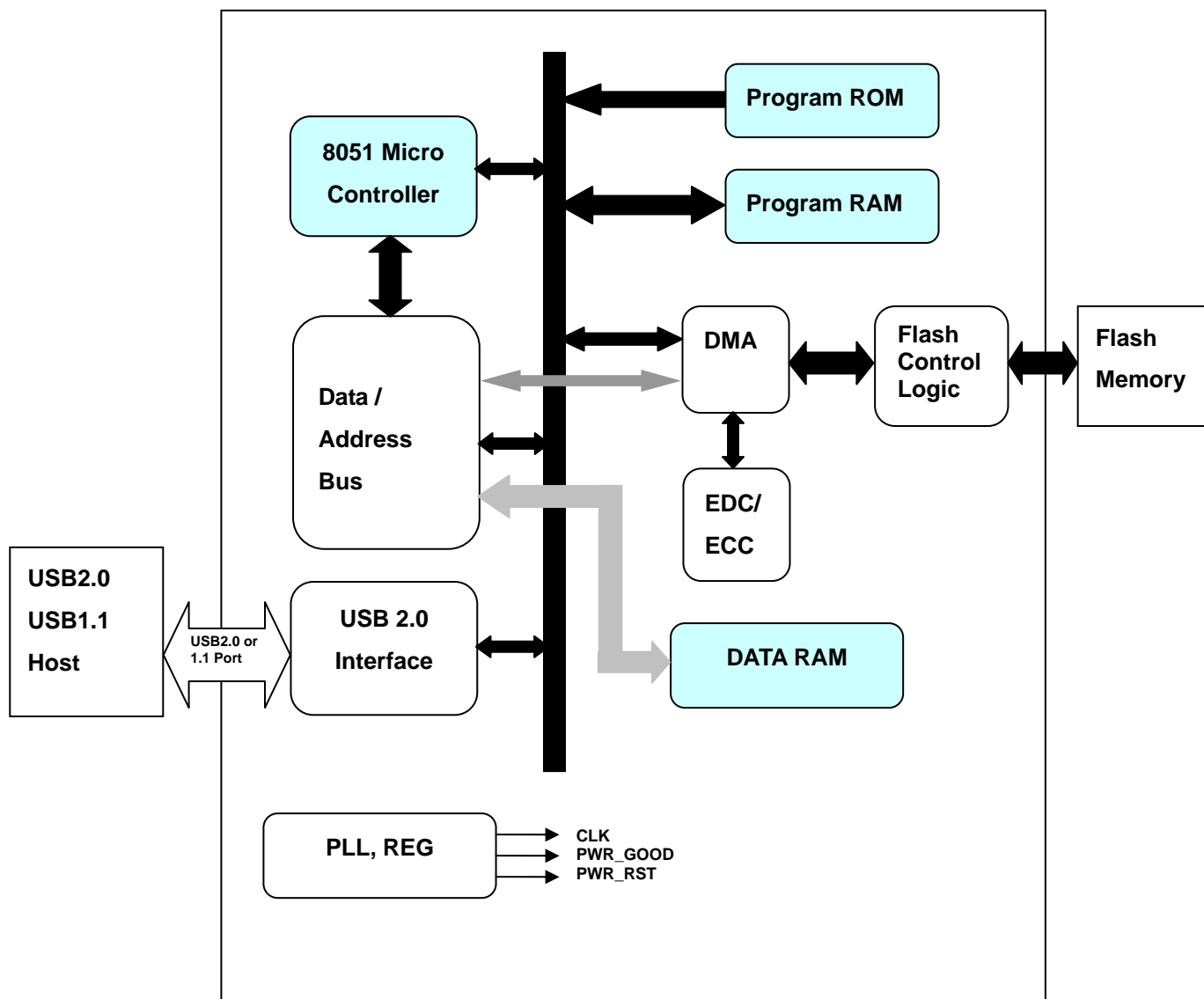

5. Absolute Maximum Ratings

Symbol	Parameter	Min	Max	Unit
T <sub>storage</sub>	Storage Temperature	-20	75	°C
T <sub>a</sub>	Ambient Operating Temperature	0	65	°C
V <sub>cc3</sub>	3.3V Supply Voltage	-0.3	3.6	V
V <sub>cc18</sub>	1.8V Supply Voltage	-0.3	2	V
V <sub>in3.3</sub>	3.3V Buffer Input Voltage	-0.3	3.6	V
V <sub>in3/5</sub>	3.3V/5V Buffer Input Voltage	-0.3	5	V
V <sub>in1.8</sub>	1.8V Buffer Input Voltage	-0.3	2	V

**6. DC Characteristics**

Symbol	Parameter	Min.	Typical	Max.	Units
V <sub>DD</sub>	Supply voltage for VCC3 or VCC3A	3.0	3.3	3.6	V
V <sub>DD18</sub>	Regulator output voltage for VCC or VCCA	1.62	1.8	1.98	V
V <sub>IL</sub>	Input Low Voltage	-0.5		0.8	V
V <sub>IH</sub>	Input High Voltage	2.0			V
V <sub>OL</sub>	Output Low Voltage (IOL=4mA)			0.4	V
V <sub>OH</sub>	Output High Voltage (IOH=4mA)	2.4			V
C <sub>IN</sub>	Input pin capacitance			10	pF
I <sub>DD</sub>	Supply current		50		mA
I <sub>SUS</sub>	Suspend current (D+1.5KΩ)			300	uA

**7. Recommended Operating Conditions**

Symbol	Parameter	Min.	Typical	Max.	Units
V <sub>CC33</sub>	Power Supply Voltage	3.0	3.3	3.3	V
V <sub>IN</sub>	Input Voltage	0	V <sub>CC</sub>	V <sub>CC</sub> + 0.3	V
V <sub>CC25</sub>	Internal Power Support	2.25	2.50	2.75	V

**8. Pin Assignments**

Pin No.	Pin Name	Function
1	VCC	USB power input
2	USB D-	USB differential signal
3	USB D+	The pairs are used to transmit Data/Address/Command
4	VSS	Ground

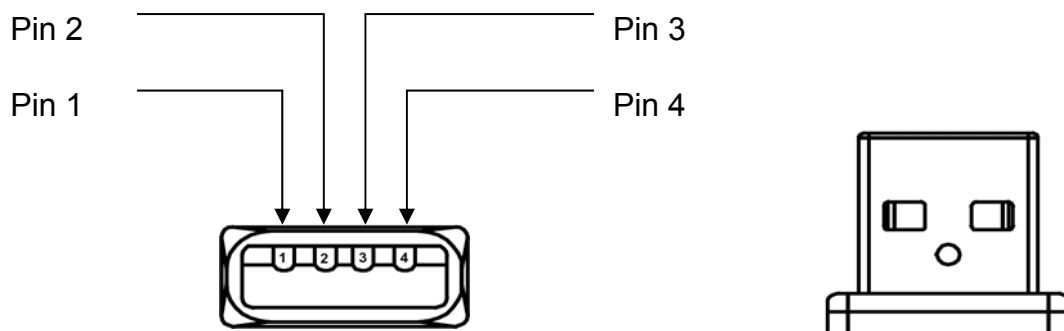

## 9. Physical Specifications

### 9.1 Dimensions:

- 9.1.1 Height: 63.2mm
- 9.1.2 Width: 17.0mm
- 9.1.3 Depth: 10.8mm
- 9.1.4 Weight: 7.8g ± 1g

### 9.2 Outline of top view

